

ROW	NUM. OF HOLES
1	20
2	20
3	20
4	20
5	20
6	20
7	20
8	20
9	16
10	8

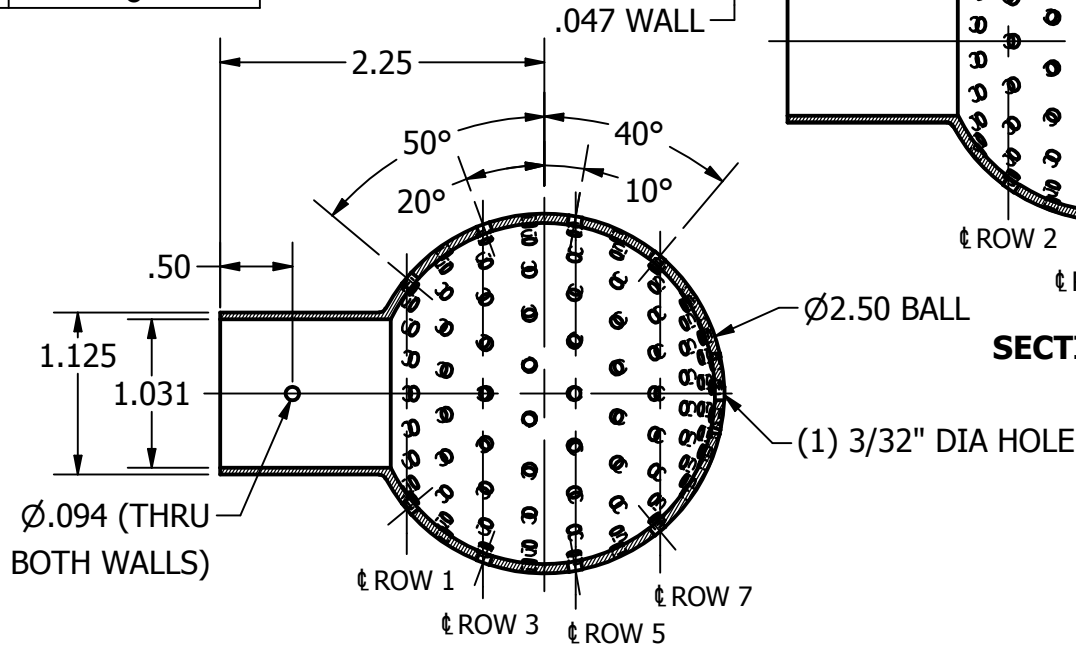

SECTION A-A

NOTES:

1. (185) 3/32" DIA. HOLES TOTAL, HOLES IN ROWS ARE EQUALLY SPACED.
2. REMOVE BURRS FROM ID/OD, MIRROR FINISH ON OD
3. MARKINGS TO BE ECHED, LEAVING A SMOOTH SURFACE.

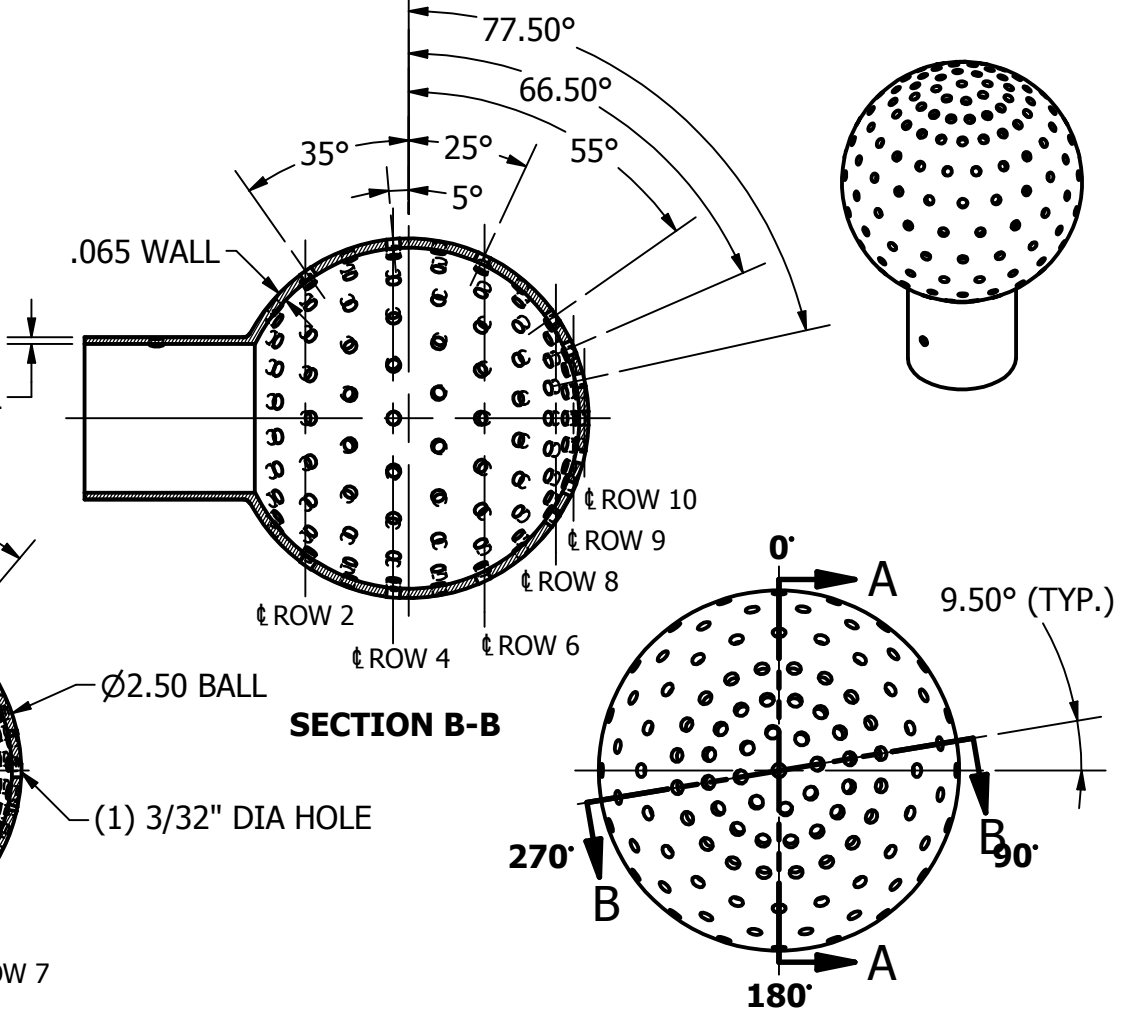

SECTION B-B



CLIP REQUIRED WITH EACH SPRAY BALL

REVISION HISTORY			
REV	DESCRIPTION	DATE	BY
1	ADDED HOLE PATTERN DETAIL	12/5/16	KL
2	ADDED MARKINGS/FINISH NOTES	12/20/16	KL

TOLERANCES		DRAWN R. Canell 3/25/2015
DECIMALS: .XX ±.015 .XXX ±.005 .XXXX ±.0005 ANGLES: 1/2°	<ALL EDGES AND FILLETS .015 R UNLESS OTHERWISE SPECIFIED <REFER TO DOC# QS121 FOR GENERAL TOLERANCES	

Steel & O'Brien Mfg. Inc.	
TITLE 1" SLIP ON x 2 1/2" SPRAY BALL WITH TYPE "A" PATTERN	
DWG NO: SBSA-1X25	REV 2
SCALE: 3 : 4	SHEET 1 OF 1