

2

1

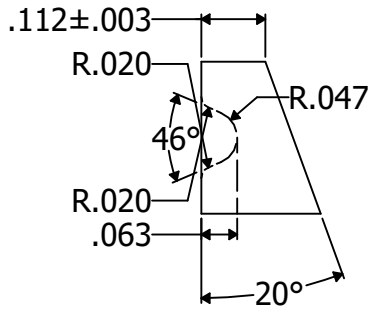

GASKET GROOVE  
14WMP-2 1/2"

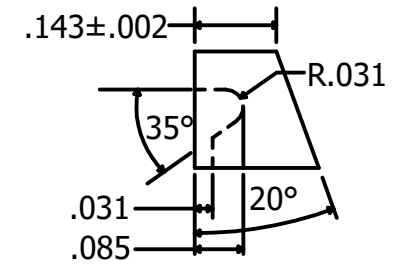

GASKET GROOVE  
14WMP-1/2"

B

B

A

A

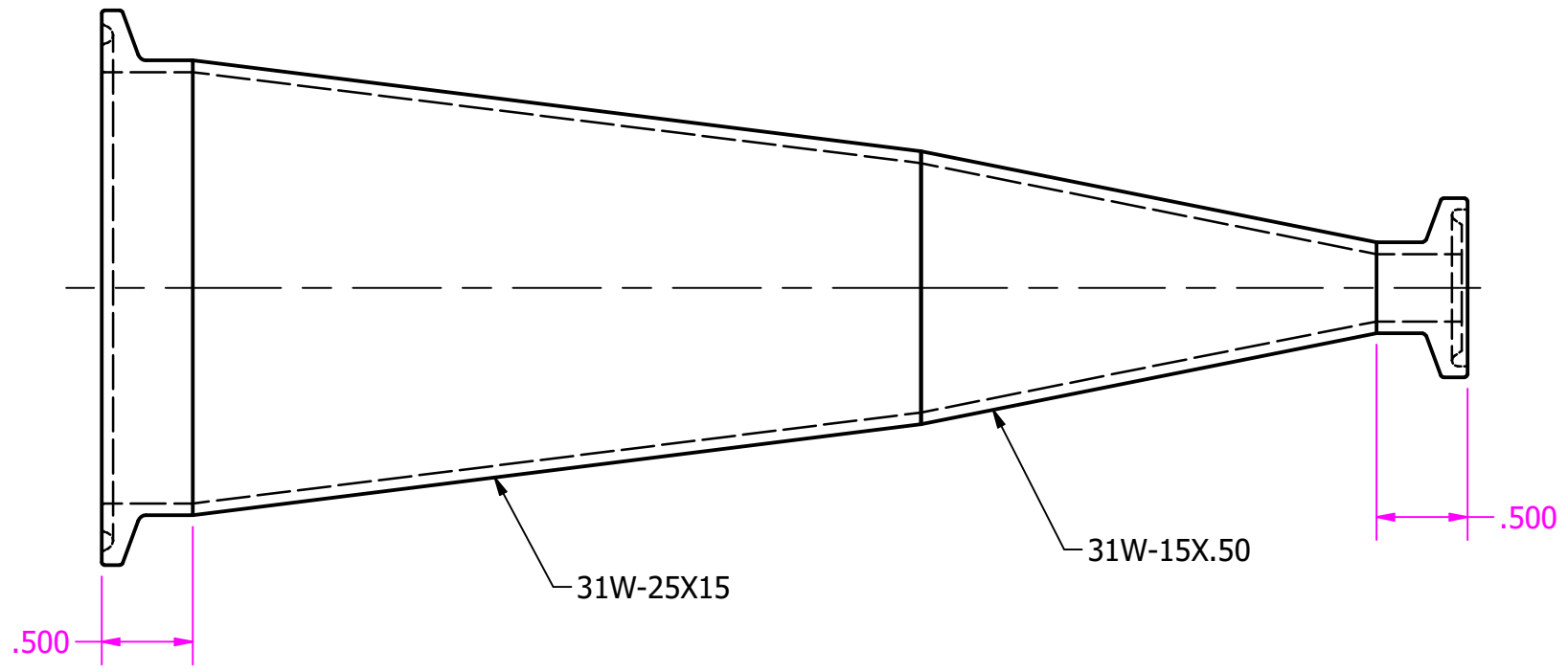

TOLERANCES		DRAWN Engineering		<b>Steel &amp; O'Brien Mfg. Inc.</b>	
DECIMALS: .XX ±.015 .XXX ±.005 ANGLES: 1°		5/9/2016			
MAT'L: 316L		<b>UNLESS OTHERWISE NOTED:</b> >PART TO CONFORM TO THE LATEST ASME-BPE SPECIFICATION FOR TOLERANCES, MATERIAL AND MARKING >ALL EDGES AND FILLETS .015 RADIUS		TITLE 2 1/2" x 1/2" TC CONCENTRIC REDUCER	
				DWG NO: <b>S31-14MP-2.5X.50</b>	
		SCALE: 1 : 1		SHEET 1 OF 1	

2

1

