

1 1/4-11.5 NPT
DEPTH OF THREAD = .0696

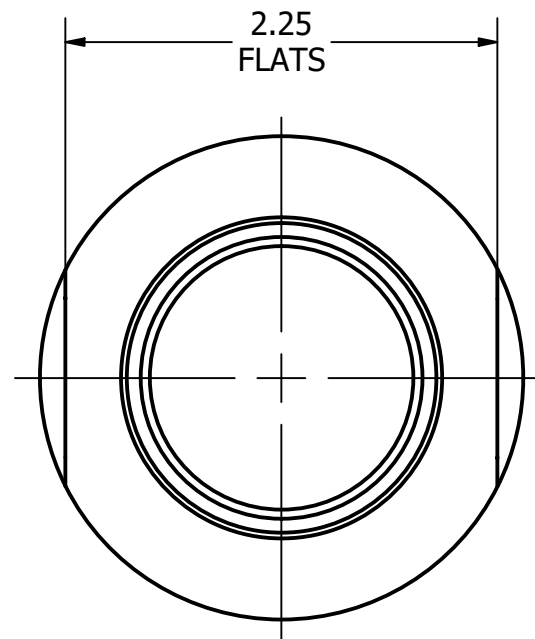

TOLERANCES		DRAWN Engineering	Steel & O'Brien Mfg. Inc.	
		4/6/2010		
DECIMALS: .XX ±.015 .XXX ±.005 .XXXX ±.0005 ANGLES: 1°		ALL EDGES AND FILLETS .015 R UNLESS OTHERWISE SPECIFIED		TITLE 2.000 TC X 1.250-11.5 MNPT 21MP
		DWG NO: 21MP-2X1.25		REV 1
		SCALE: 1 : 1		SHEET 1 OF 1